

# ROBOT de copie BoxWriter BW7270



## **BoxWriter Automatic Disc Duplicator**

Model #: BW7220 (BoxWriter Standalone)

Serial Number: \_\_\_\_\_

(Serial number is labeled on the rear panel of the device.)

---

## PREFACE

**C**ongratulations! You have just purchased an innovative BoxWriter auto-duplicator. Your BoxWriter is a state-of-the-art automated optical disc duplicating device that does not require host computer connection, the embedded controller and built-in hard disk provide reliable duplication performance.

BoxWriter BW7220 is a twin recorder duplicator to output twice of a single drive duplicator. Having a capacity of 80 discs, the lock-secured enclosure keeps discs away from dust and unauthorized access. In case failed disc is detected, it will be separated from the good ones.

Getting BoxWriter on the road is simple. Plug in the power cord, turn on the power, load discs, and you are ready to go!! The user-friendly LED panel and buttons take only minutes to learn. Copying discs is as easy as 1-2-3; just load master and blank discs, push button, and the duplicate discs are on the way to burn.

This manual provides the necessary information on the operation and maintenance of your BoxWriter. It is strongly recommended that you shall read throughout the manual before getting on road.

Please visit our website for additional information regarding optical disc duplication, printing and management. Your opinion and suggestion are always welcome.

Thank you for supporting us with the purchase of our product.

### **Warning...**

It is illegal to duplicate copyright materials, including but not limit to computer software, games, audio CD, VCD, and DVD. Violators may subject to fine or prosecuted under the federal and applicable laws. Some vendors may allow a reasonable backup of the disc, but not all do. If you are not sure about the copyright policy of an optical disc, contact the original publisher.

### **Important Safety Instructions**

For your safety, basic precautions should always be followed to reduce risk of damage, electric shock, fire, and personal injury. This includes the followings:

- Read this manual carefully and follow all warnings and instructions.

- Use only 3-wire extension cords that have 3-prong grounding plugs and 3-pole grounding receptacles that accept your device's plug. Make sure the device is connected to a known ground.
- Do not place in direct sunlight. Make sure the environment is free from any abrupt or humidity changes.
- Keep away water, flammable material, gas, dust, dirt, smoke, and pollution.
- Place this device on a steady level surface.
- Do not move this device while the power is on. Handle it with care, especially the fragile parts.
- Place this device in an air-conditioned environment. Allow space for ventilation of clean, cool air. This device generates heat during burning process. Overheat may lower output quality, increase failure rate, and cause damage to the device.
- Use a reliable power source with a correct voltage and ample current supply. Out-of-specification or unstable power may lower its productivity, increases failure rate, and might also damage the device.
- Give this device a dedicated power outlet. Do not share outlet with other devices.
- Make sure the power cord is secured. Always turn off the power when connecting to the power cord or cable.
- It shall be a good habit to always unplug the power cord before trouble-shooting and maintenance.
- Do not attempt to disassemble this device. Take it to a qualified service technician when repair work is required. Un-authorized disassemble or repair will definitely void all warranty.
- Do not touch any moving parts to avoid injury or damage.

### **Acknowledgments**

Copyright © 2008, BoxWriter

All rights reserved. Reproduction, adaptation, or translation without prior written permission is prohibited, except allowed under the copyright laws.

trademarks are property of their respective owners.

## **FCC Regulations**

This equipment has been tested and founded to comply with the limits for a Class A digital device, pursuant to Part 15 of the FCC rules. These limits are designed to provide reasonable protection against harmful interference in a residential installation. This equipment generates, uses, and can radiate radio frequency energy. If this equipment is not installed and used according to the instructions, it may cause damaging to the radio communications. However, there is no guarantee that interference will not occur in a particular installation. If this equipment does cause harmful interference to radio or television reception, which can be determined by turning the equipment off and on, the user is encouraged to correct the interference by one or more of the following measures:

- Reorient or relocate the receiving antenna.
- Increase separation between equipment and receiver.
- Connect equipment to an outlet on a circuit different from that to which the receiver is located.
- Consult your dealer or an experienced radio/TV technician.

Use of a shielded interface cable is required to comply with the Class A limits of Part 15 of FCC rules.

## **Limited Warranty (North America only)**

For certain parts made by other manufacturers, such as hard drives, disc readers and writers, the original manufacturer's warranty applies.

This warranty is not covered when product has been abuse, misuse, alteration, modification, tampering, negligence, faulty installation, accident, lack of reasonable care, un-authorized repairing or service, or if affixed to any attachment not provided with the product, or if the serial number label comes with this product is broken or remove.

This warranty does not cover damages that occur in shipment, due to act of God.

All repair and replacement services shall only be handled by Datatronics Technology Inc, and by the authorized service centers. Parts used for replacement are warranted only for the remainder of the warranty period.

## **Technical Support**

For technical question and assistance, your dealer and distributor are the first hand service providers. Always contact your dealer and local distributor for immediate support.

---

**TABLE OF CONTENTS**

---

<b>Preface</b>	<b>2</b>
Important Safety Instructions .....	2
Acknowledgments .....	3
<b>Installation of BoxWriter</b>	<b>7</b>
Unpacking the Package .....	7
Checking the Package Contents.....	7
Getting Familiar with Your BoxWriter .....	7
The Rear Panel of BoxWriter .....	8
Block Diagram of BoxWriter .....	8
LED Indicator Definitions .....	9
<b>Specification of BoxWriter</b>	<b>10</b>
<b>Before You go</b>	<b>11</b>
Cautious about Handling Optical Discs .....	11
Things That You Should Need .....	11
Tips about Loading Discs to BoxWriter.....	11
Verify Discs .....	12
Failure in Writing Discs .....	12
Abort a Running Operation .....	13
<b>Quick Guide of BoxWriter Operation</b>	<b>15</b>
Copy Discs (High and Safe Speed) .....	15
Simulation of Burning Discs .....	15
Erase a Stack of Rewritable Discs .....	16
Verify a Stack of Discs .....	16
<b>Appendix</b>	<b>17</b>
Maintenance of BoxWriter.....	17
Choosing Reliable Blank Disc.....	17
Sticky Disc.....	17
Production vs. Yield Rate.....	17
Writing Speed.....	18
<b>Frequently Asked Questions</b>	<b>19</b>

## **INSTALLATION OF BOXWRITER**

### **Unpacking the Package**

Carefully follow the instructions outside the package to unpack. Before opening the package, carefully inspect the carton for damage. If any sign shows damage, contact the shipping company and your dealer immediately.

Save the packing materials for future shipment use. Returning goods without original package may not be well protected during transportation, and will void your warranty.

### **Checking the Package Contents**

Separate all parts from packing materials. If any part is missing or damaged, contact your dealer immediately. The items listed below should be included in the package:

- One BoxWriter BW7220 auto-duplicator unit;
- One power cord;
- This operation manual.

### **Getting Familiar with Your BoxWriter**

The picture below illustrates BoxWriter in front appearance. The power socket and switch are located at the rear.

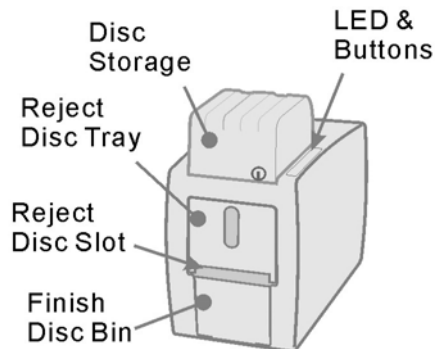

- **LED & Buttons:**  
On top of BoxWriter, the control panel is with LED indicators and button switches on it.
- **Disc Storage:**  
The cabinet for discs storage, secured by lock. Turn the key to unlock and lift it to open. The lock also secures Finish Bin.
- **Reject Tray:**  
Pull-open this tray to receive rejected discs (capacity: 3 discs).
- **Reject Slot:**  
The slot where rejected discs will come out when Reject Tray is at its close position.

- **Finish Bin:**  
The drawer for finish disc storages. Make sure to unlock Disc Cabinet before pull out the bin.

**Note:**

The Finish Bin has to be in position during operation. Pull out the Finish Bin will stop BoxWriter operation right after the current burning disc had completed.

## The Rear Panel of BoxWriter

- **Ventilation:**  
For heat exchange purpose. DO NOT block the outlet.
- **Power Socket:**  
Connect to wall outlet with the power adaptor come with BoxWriter.
- **Power Switch:**  
Turn on and off BoxWriter.

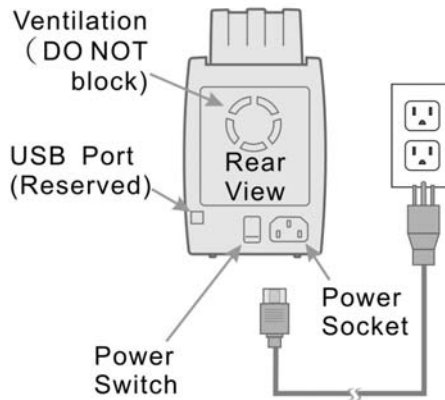

## Block Diagram of BoxWriter

In refer to the illustration to the right, your BoxWriter BW7220 auto-duplicator is an integrated system built-in with dual optical disc recorders, a hard disc and an auto-loader. Depending on the configuration of your purchase, it shall come with the corresponding CD, DVD or Blu-Ray recorders.

BoxWriter BW7220 (Standalone)

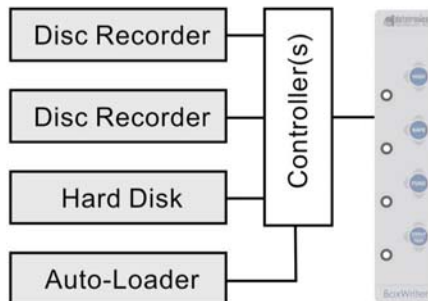

## Control Panel of BoxWriter BW7220

Refer to the illustration for the switches and LED indicators on the control panel:

- **High Speed Copy:**  
Start highest speed duplication for maximum production output.

- **Safe Speed Copy:**  
Start normal speed duplication; trade-off output rate for better quality. Recommended for audio and video discs.
- **Function Key:**  
Toggle to activate or de-activate disc verify function.
- **Test/Abort**  
Abort the current duplication job; or, start burning simulation.



For the meanings of LED indicator combination, see the LED Indicator Definitions section later in this manual.

### LED Indicator Definitions

The LED indicators on the panel reflect the current status of BoxWriter. The table below describes the meaning of indicator configuration.

H	S	F	T	Description
●	●	●	●	Power-off.
⇒	⇒	⇒	⇒	Initialization is undergoing.
●	●	●	○	Ready mode.
◎	●	●	○	Running High-speed copy.
●	◎	●	○	Running safe-speed copy.
◎	●	○	○	Running high-speed copy with verify.
●	◎	○	○	Running safe-speed copy with verify.
●	●	◎	○	Running disc verify.
⇒	⇒	⇒	○	Running rewritable disc erase.
◎	◎	◎	○	Output bin is full.
◎	◎	○	○	Re-position Finish Disc Bin to resume operation.
●	●	●	◎	Error is encountered.
●	●	○	●	Function key has been pressed.

○: Lit      ●: Off      ◎: Flash      ⇒: Running

---

## SPECIFICATION OF BOXWRITER

---

Disc Drive	Two DVD/CD recorders (BW7220); Two Blu-Ray/DVD/CD recorders (BW7220BR).
Input Capacity:	80 discs.
Output Capacity:	80 discs.
Write Speed:	CD-R: 40X; CD-RW: 32X; DVD±R: 18X; DVD±R Dual: 10X; DVD-RW: 6X; DVD+RW: 8X. Blu-Ray: 4X (BW7220BR only).
Operation Method:	Standalone operation; LED indicators and push buttons on control panel.
Push Buttons:	High-speed, Safe-speed, Function and Test/Abort; with corresponding LED indicators.
Disc Size:	120 mm in diameter.
Operation Temperature:	42°F to 86°F ( 6°C to 30°C).
Humidity:	5% to 85%, no condensation.
Certification:	CE and FCC; power adaptor is UL approved.
Dimensions:	9-1/2" x 17" x 17-1/2"; 23.9 x 44.9 x 47.4 cm.
Weight:	22 lb; 10 kg.
Power:	100 to 240VAC; 50 or 60 Hz.

\* Specifications are subject to change without notice.

## BEFORE YOU GO

### Cautious about Handling Optical Discs

NEVER touch the printable and data surface of the disc, it may decrease quality and life span of the disc. Refer to the arrows on the illustration at the right, always handle discs by the outer edge or the center hole.



### Things That You Should Need

The BoxWriter BW7220 is a standalone duplicator, which does not require computer connection. You shall need:

- Master discs:  
The original disc that provides the source of data in a duplication job.
- Blank discs:  
The recordable disc to which the data from the master disc will be duplicated on.

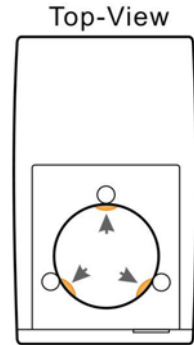

### Tips about Loading Discs to BoxWriter

At first, carefully load one disc to the loader and well assure that it is firmly rested on the flanges of separator wheels (refer to arrows on the illustration). Then, load additional discs gently on top of it.

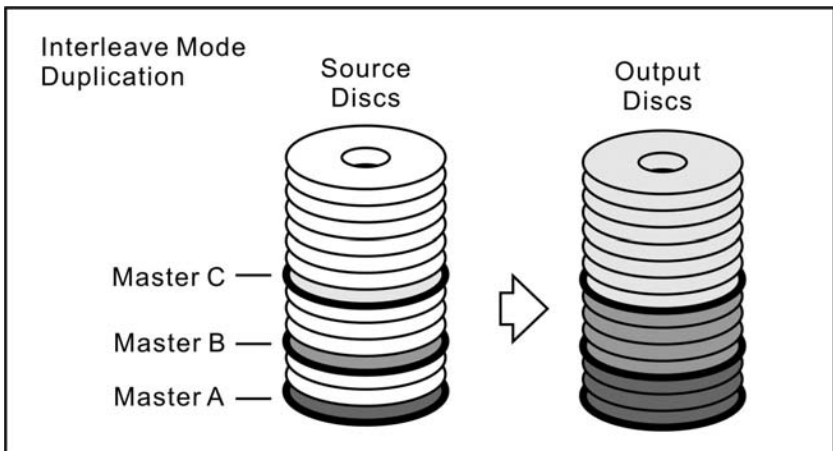

The loader capacity is 80-discs. As shown on the illustration, one after another, load exact quantity of blank discs on top of master disc.

Loading multiple groups of master and blank discs is acceptable. BoxWriter is designed to read master disc to hard disk to image file, then, make duplicate discs by writing the image from the hard disk to blank discs, until the loader runs out of discs. Every disc detected with data on it will be treated as master disc.

To refill, simply reload additional discs on top before the loader become empty.

### **Verify Discs**

Verify duplicate disc involves read and compare; that is, check the readability of disc and compare the data accuracy with the original disc or image file.

When doing verify, BoxWriter will firstly detect the format of disc. If it is CD data, DVD or Blu-Ray format, the disc will be completed with both readability and compare processes. However, due to limitation of related technical standards, verify of audio discs shall involve only readability check, compare process will not be executed.

### **Failure in Writing Discs**

Some disc might be bad and not be successfully written data on it. During automated operation BoxWriter is designed with the following rules when encounters failure:

- 1) In a dual-drive burning session, if one of the drives failed to write discs for three continuous attempts, the drive will be isolated and BoxWriter will enter single drive operation. The current work will continue with the other drive only.
- 2) In a single-drive burning session, if the drives failed to write discs for three continuous attempts, BoxWriter will stop the current job and the LED indicators will show up error.
- 3) No matter high or safe speed copy, in a burning session if in total accumulated ten failures, BoxWriter will stop the current job and the LED indicators will show up error.

#### **Note:**

To resume operation from an error, clear up the problem cause and press the appropriate key to restart the work. In certain case you may have to turn BoxWriter off, wait 30 seconds, and turn it back to on.

## Abort a Running Operation

To abort an undergoing operation, press and hold the Test/abort button for 2 seconds. If it is during a burning session, the BoxWriter is designed to stop the operation after the current burning had completed.

### Note:

Turn off the power switch of BoxWriter shall immediately terminate the current operation, yet the disc existing in recorder may become damaged. DO NOT do so unless emergency.

## Finish Disc Bin is Full or Out-of-Position

Once the Finish Disc Bin is full, the LED indicators will signal error. BoxWriter will stop although the next disc is holding for unloaded. To resume, clear the Finish Disc Bin, return it to position and press any key.

If the Finish Disc Bin had been moved out-of-position before full, BoxWriter will continue until the current burning session had completed. Then, when it is to unload the just finished disc, LED will signal error and BoxWriter will stop.

## Turning on your BoxWriter

Follow the steps below to get your BoxWriter ready:

- 1) Connect the power cord:
- 2) Plug in the power cord to the rear panel of the device, and connect the cord to a wall outlet.
- 3) Turn on the power switch at rear panel, BoxWriter will enter initialization process, including remove any disc existed in its optical drives.

### Note:

The Finish Bin must be in position during operation. Pull of the Finish Bin will stop BoxWriter operation right after the current burning disc had completed.



### Warning...

Always use a reliable power source of correct voltage with ample current supply. An out-of-specification or unstable power supply may decrease output rate, down grade output quality, increase failure rate, and could damage your BoxWriter.

During initialization, LED indicators will go and go running in sequence. Be patient until the initialization had completed.

When the initialization is completed, indicator by Test/Abort button will be lit (as shown at the right, with other indicators are off). BoxWriter is now ready to work.

To turn off BoxWriter, press the power switch at rear panel. In case there is undergoing session, abort it or wait until completed.

## QUICK GUIDE OF BOXWRITER OPERATION

### Copy Discs (High and Safe Speed)

High Speed Copy mode produces maximum output rate, yet it is not recommended for audio and video duplication.



In Safe Speed Copy mode, better duplication quality trades-off with production rate, especially recommended for duplicating audio and video discs.



Follow the steps below to do it:

- 1) Load master disc to the loader.

**Note:**

In copy mode whenever a rewritable disc is detected, BoxWriter is designed to always erase the disc. Therefore, do NOT use rewritable disc as master disc as it will firstly be erased.

Load desired quantity of blank discs on top of the master.

Repeat step 1 & 2 to load another set of master and blank discs.

- 2) Press either High or Safe Speed Copy button to start. BoxWriter will run the operation until the loader becomes empty.

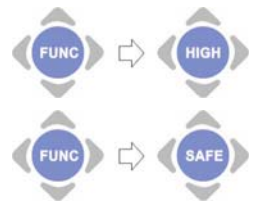

**Note:**

To verify-after-burn, firstly press Function Key to light up the LED next to the button; then press High or Safe Speed Copy to start.

### Simulation of Burning Discs

This mode is to physically test discs for burning usage, by emulating the burning process, but does not actually write discs. Follow the steps below to do it:

- 1) Load master disc to the loader;

- 2) Load desired quantity of blank discs on top of the master.
- 3) Press Test/Abort button to start. BoxWriter will run the operation until the loader becomes empty.



**Note:**

Due to technical standards, simulation does not apply to DVD+R, DVD+RW and DVD+R DL discs; therefore, “DVD+” discs will always be rejected.

### Erase a Stack of Rewritable Discs

Using simulation function, BoxWriter can quick-erase a stack of CD and DVD rewritable discs. Follow the steps below to do it:

- 1) Load to BoxWriter the rewritable discs to be erased.
- 2) Press Test/Abort button to start. BoxWriter will erase discs until the loader becomes empty.



Test/Abort

### Verify a Stack of Discs

This mode is to verify a stack of duplicate discs with the original master disc. Follow the steps below to do it:

- 1) Load to BoxWriter the original master discs and the discs to be verified.
- 2) Press Function Key to light up the LED next to the button; then press Test/Abort to start.



---

## APPENDIX

### Maintenance of BoxWriter

Periodically clean the device can ensure the performance. Follow the steps below for maintenance.

- 1) Turn off power switch.
- 2) Remove master and blank discs.
- 3) Unplug the power cord from wall outlet.
- 4) Use a clean lint-free cloth moistened with warm water.
- 5) Dry the unit immediately with a clean lint free cloth.

### Choosing Reliable Blank Disc

There are many recordable CD and DVD on the market, with different writing speed and package. Among them are always pro and cons, and trade-offs. Not all of them work perfectly in every case. Unfortunately, we are unable to test them all.

Please choose the blank disc that is most suitable for your application. We strongly suggest users test the blank discs by using simulation mode before the actual burning duplication. You may contact your local dealer for advice and supply for the best suitable blank disc to the unit and your application.

### Sticky Disc

Certain blank discs may tend to stick to each other and are hard to be separated. Avoid those sticky discs as possible.

BoxWriter is equipped with innovative patent-pending powerful separator, which will handle sticky discs better than many other auto-duplicators; however, it is strongly recommended, always shuffle to loose blank discs before use.

### Production vs. Yield Rate

The quality of master disc and the data format also play critical roles in a burning job and the quality of the discs produced. If you keep encountering difficulties, try Safe Speed copy mode. In many cases the production rate shall successfully trades off the yield rate.

BoxWriter BW7220 can be chosen to make duplication at either high or safe speed, simply by pushing the corresponding button respected. Note that selecting a high-speed does not mean the writing speed will

be fixed at maximum. The system will monitor and automatically adjust the burning speed as the optical laser moves from the inner ring to the outer ring, up to the speed selected.

### **Writing Speed**

Disc drive will automatically adjust burning speed according to the quality of disc. It starts burning at a lower speed then gradually increases to a higher speed up to the maximum allowable speed. Depending on the quality of disc, the drive's maximum speed may never be reached if lower graded disc is used.

The quality of a disc depends on its coating chemical and technologies. There are a variety of discs available on the market, unfortunately, the quality are also different. If you encountered high failure rate, please try different type/brand of discs or reducing the writing speed.

BoxWriter BW7220 provides two burning speeds for your convenience. By pressing the High Speed Copy button, the device will operate under the maximum possible writing speed. Therefore, the maximum production rate can be expected.

At the maximum speed, burning a 4.7 GB DVD shall take no more than 8 minutes (by single drive). If it takes longer, please check both the quality of the blank and the master disc. Use a reliable master disc for testing purpose. Change blank discs to different brand or specification.

You should also check the power supply for amperes. Insufficient power supply may decrease output rate, and/or, increase failure rate.

If you press the Safe Speed Copy button, the device will be restricted to copy under a low speed. The burning quality can be better assured. When burning audio discs of music, this safe writing speed is recommended.

---

## FREQUENTLY ASKED QUESTIONS

---

**Q: Burning failure rate is high.**

- Try a lower writing speed such as Safe Speed Copy.
- Use different brand of blank discs.
- Check power source.

**Q: Disc jam during operation.**

- Check if the disc is in standard size. (120mm)
- Make sure discs are leveled in the input hopper.
- Reduce the quantity of disc per load. Some discs are too weak or soft.
- Use different brand of blank discs.

**Q: The power switch does not work every time.**

Allow 10 seconds interval between turn on/off.

**Q: Robotics arm fails to pick up the discs.**

- Check if the disc is in standard size. (120mm)
- Make sure the discs are not out of shape.

**Q: Dropping two or more discs at the same time.**

- Check if the disc is in standard size. (120mm)
- Make sure discs are leveled while inserted.
- Loose discs before use. Some discs may stick together.
- Use discs of the same brand/lot. Do not mix discs.
- Reduce the quantity of disc per load. Some discs are too weak or soft.
- Use different brand of blank discs.

**Q: How can I recover BoxWriter from hanging?**

Turn off the power switch, and turn it back on after 30 seconds. If a power-on reboot cannot solve the problem, please contact your dealer, authorized service center, or e-mail us.

